

General Description

Series VMY*K valves consist of the main stage with valve spools and the pilot stage with the proportional solenoids. The desired pressure can be variably set corresponding to the command signal specified on the amplifier. The proportional solenoid converts the current of the amplifier into force on the valve poppet of the pilot stage.

In the pilot stage, there is a flow limiter which supplies the pilot valve with pressure-independent pilot oil flow from the pressure port P.

The proportional pressure reducing/relieving valves of the series VMY*06 allow the variable adjustment of the reduced pressure from 0 bar up to p_{max} . Typical applications are pressure systems, test equipment, or counterweight systems. The electrical control of the valve takes place using the digital amplifier module PCD00A-400. Used in closed loop pressure control circuits with the PWDXXA-400.

Function

With the proportional solenoids de-energized the main spring forces the main spool into the neutral position. Port A is connected to port T. Thus the reduced pressure only depends on the back pressure in the external drain pipe and/or the tank pressure and can accordingly be reduced down to 0 bar. The pressure present in the P line delivers the pilot oil to the pilot stage via a flow control valve.

VMY*K06N

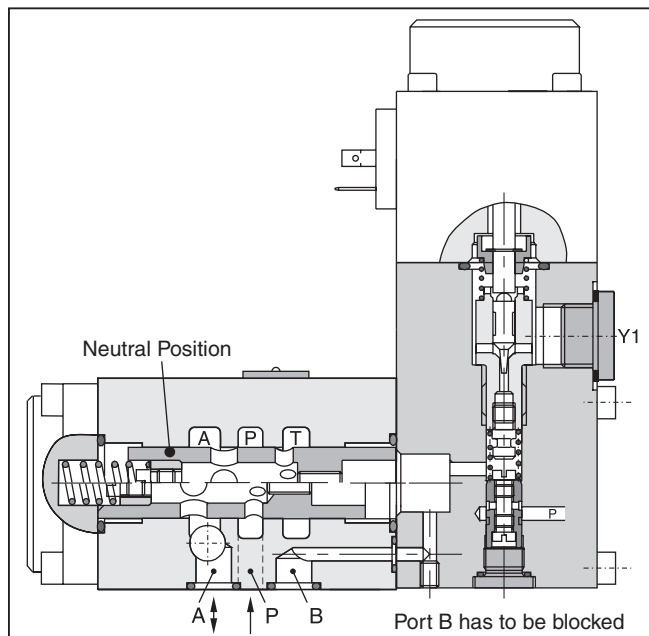

! WARNING: This product can expose you to chemicals including Lead, Nickel (Metallic), or 1,3-Butadiene which are known to the State of California to cause cancer, and Lead or 1,3-Butadiene which is known to the State of California to cause birth defects and other reproductive harm. For more information go to www.P65Warnings.ca.gov.
 B01_Cat2550.indd, ddp, 04/19

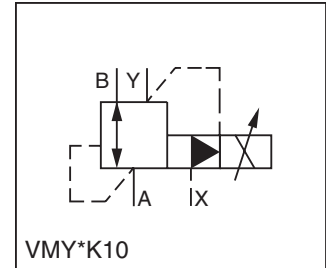
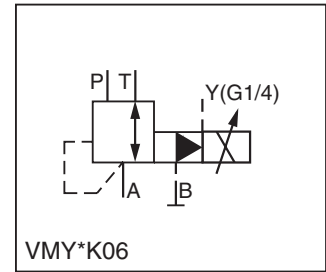

When the proportional solenoid is energized, the pilot pressure is increased in the pilot pressure area, and the main spool moves against the spring until the connection P - A opens. The regulation of the reduced pressure on connection A takes place by the constant comparison of the actual pressure and the reference pressure of the pilot stage.

Features

- Consistent performance
- Variable adjustment
- Pilot operated with proportional solenoid
- Subplate according to ISO 5781

VMY*K10

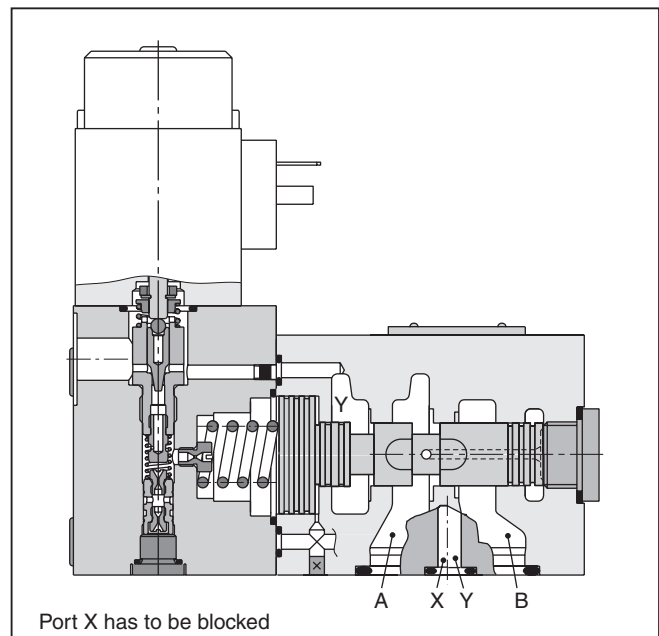

B

Ordering Information

VMY

Reducing/
Relieving
Valve

□

Pressure
Range

K

Linear
Solenoid
9V / 2.5A

□

Size

□

Pilot Oil

□

Seal

1

Design
Series

P

High Pressure
Channel

Code	Description
064	64 Bar (928 PSI)
100	100 Bar (1450 PSI)
160	160 Bar (2320 PSI)
210	210 Bar (3000 PSI)
315	315 Bar (4568 PSI)

Code	Description
06	NG6
10	NG10

Code	Description
N*	Nitrile
V	Fluorocarbon

* Size 10 only

Pilot Oil				
Code	Size	Pilot	Drain	p _{min}
Omit	10	Internal	Internal	3 - 4 Bar (43.5 - 58 PSI)
N ¹⁾	06	Internal	External ²⁾	0.5-1 Bar (7 - 14.5 PSI)
T	06	Internal	Internal	1-2 Bar (14.5 - 29 PSI)

¹⁾ Connection on port Y

²⁾ p_{min} = 0 Bar (0 PSI) possible

Weight:

VMY*06 2.8 kg (6.2 lbs.)
 VMY*10 5.0 kg (11.0 lbs.)

Specifications

General	
Design	Proportional Reducing/Relieving Valve
Size	NFPA D03 / CETOP 3 / DIN NG6 DIN NG10
Mounting Pattern	ISO 5781
Actuation	Proportional Solenoid
Mounting Position	Any
Ambient Temperature	-20°C to +80°C (-4°F to +176°F)
Hydraulics	
Operating Pressure, Ports	Ports P, A 315 Bar (4500 PSI) Ports T, Y depressurized; Port B has to be blocked Ports A, B 350 Bar (5075 PSI) Port Y depressurized; Port X has to be blocked
Flow	40 LPM (10.6 GPM) 160 LPM (42.2 GPM)
Pilot Flow	0.3 - 0.4 LPM (.08 - .011 GPM), not dependent on pressure
Pressure Ranges	64, 100, 160, 210, 315 Bar (928, 1450, 2320, 3045, 4568 PSI)
Fluid	Hydraulic oil as per DIN 51524...51535, other on request
Fluid Temperature	Recommended Permitted +30°C to +50°C (+86°F to +122°F) -20°C to +70°C (-4°F to +158°F)
Viscosity	Recommended Permitted 30 to 50 cSt / mm ² /s (139 to 232 SSU) 20 to 380 cSt / mm ² /s (93 to 1761 SSU)
Filtration	ISO 4406 (1999) 18/16/13 (acc. NAS 1638: 7)
Linearity	See Performance Curves ±3.5 at >15% p _{nom}
Repeatability	<±2%
Hysteresis	<3%
Response Time	<150 ms <200 ms
Electrical	
Duty Cycle	100% ED; CAUTION: Coil temperature up to 150°C (302°F) possible
Protection Class	IP65 in accordance with EN 60529 (plugged and mounted)
Nominal Voltage	9 VDC
Maximum Current	2.5 A
Ambient Temperature	-20°C to +70°C (-4°F to +158°F)
Coil Resistance	2.1 ohm at 20°C (68°F)
Plug Connectors	2 pole + PE / connector EN 175301-803 / cable Ø 8 to 10mm
Power Amplifier	PCD00A-400

B01_Cat2550.indd, ddp, 04/19



Pressure Curves where $p = f(U_{set})$

Setting Range max. 64 Bar (928 PSI)

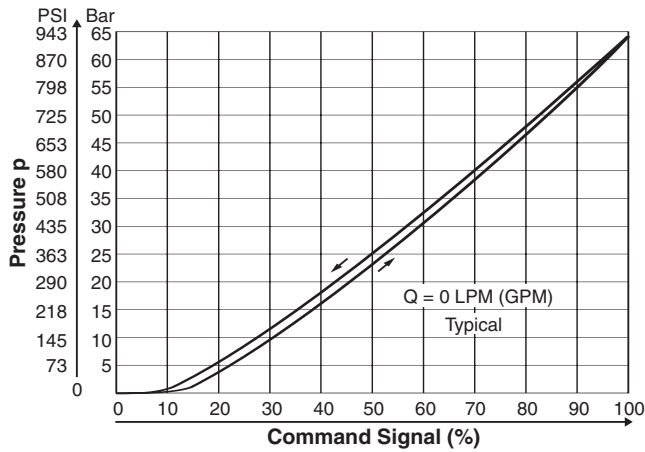

Setting Range max. 210 Bar (3045 PSI)

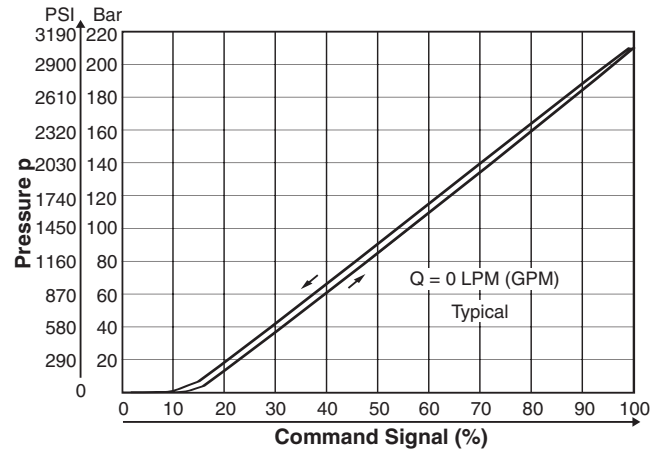

Step Response

Typical Curve

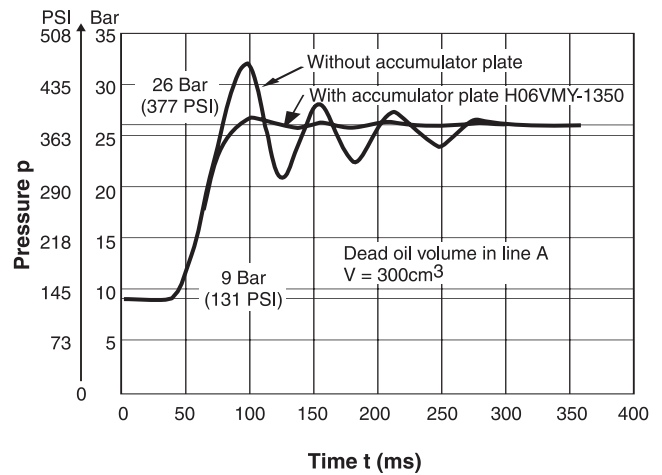
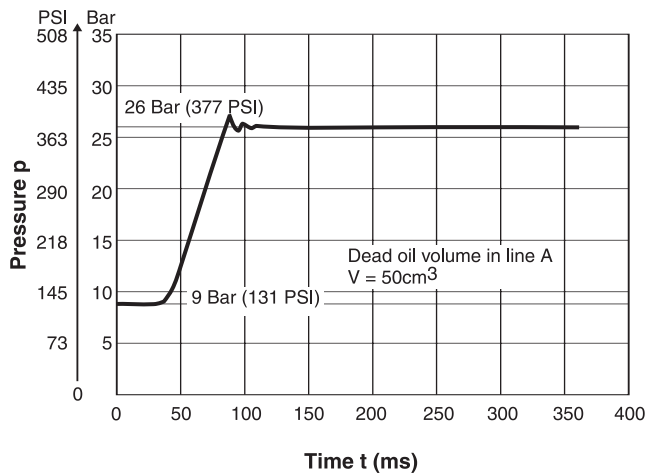

Accumulator Plate H06VMY-1350

Inch equivalents for millimeter dimensions are shown (**)

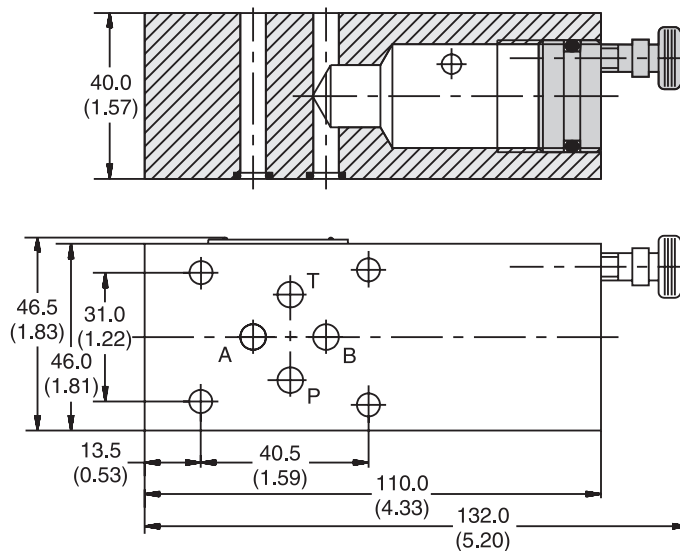

B

p/Q Performance Curves measured at $t = 50^{\circ}\text{C}$ (122°F) and $v = 35\text{mm}^2/\text{s}$.

Setting Range max. 64 Bar (928 PSI)

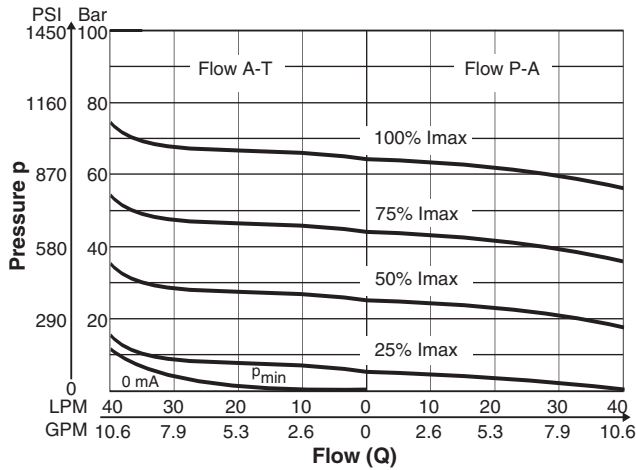

Setting Range max. 100 Bar (1450 PSI)

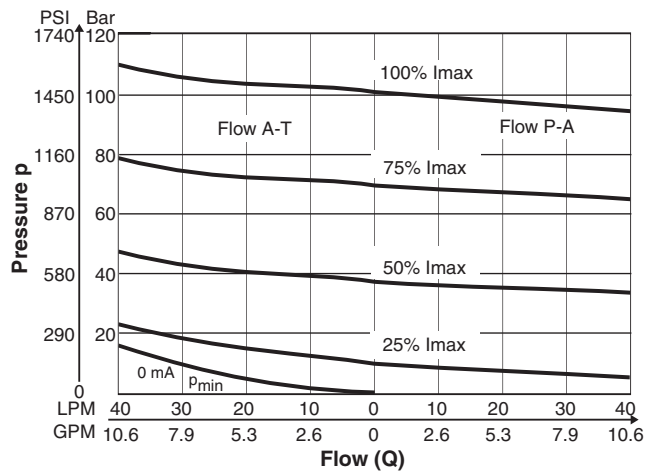

Setting Range max. 160 Bar (2320 PSI)

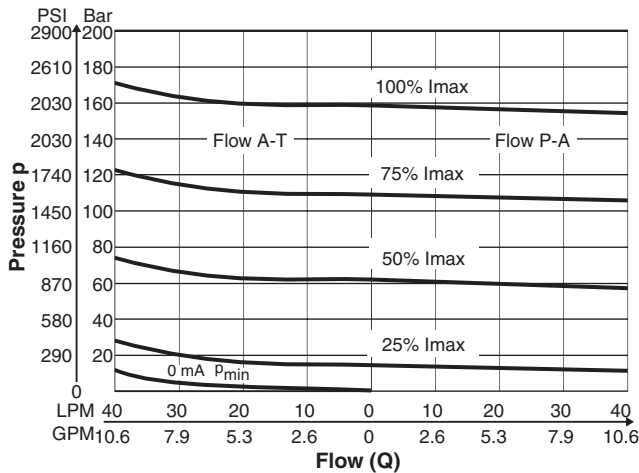

Setting Range max. 210 Bar (3045 PSI)

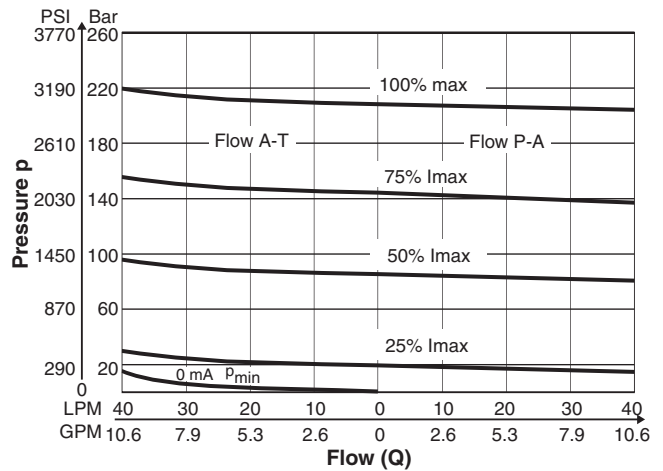

Setting Range max. 315 Bar (4568 PSI)

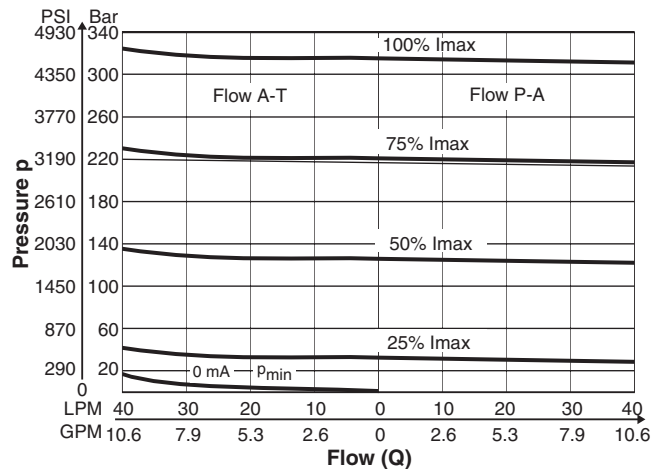

p/Q Performance Curves for pilot oil supply from high pressure channel P, measured with HLP46 at 50°C (122°F).

Setting Range max. 64 Bar (928 PSI)

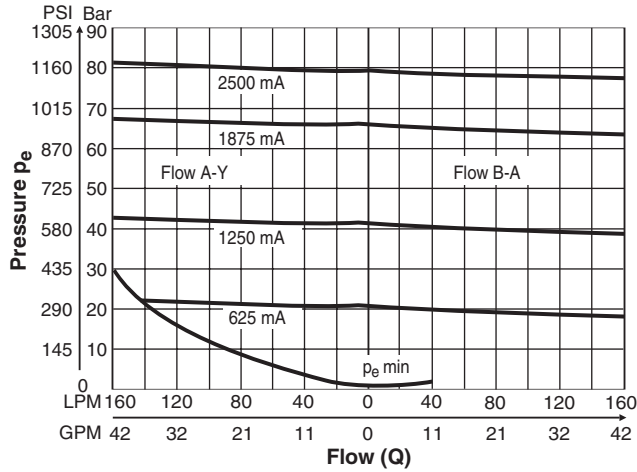

Setting Range max. 100 Bar (1450 PSI)

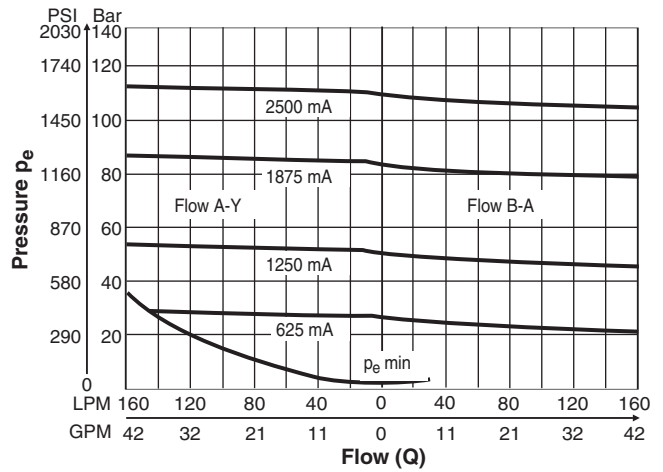

Setting Range max. 160 Bar (2320 PSI)

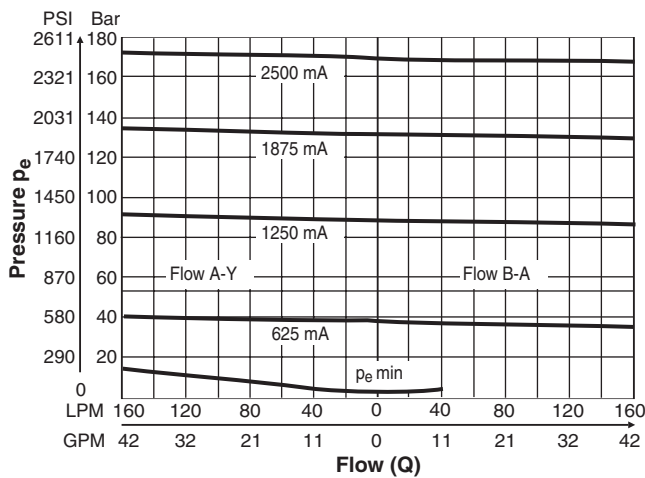

Setting Range max. 210 Bar (3045 PSI)

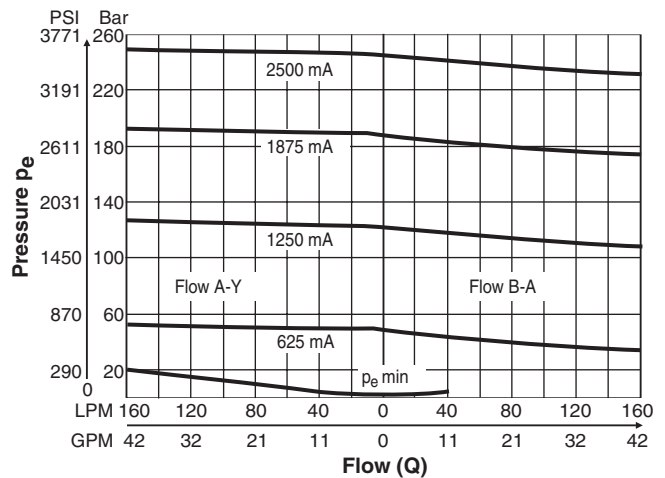

B

Size NG6

Inch equivalents for millimeter dimensions are shown in (**)

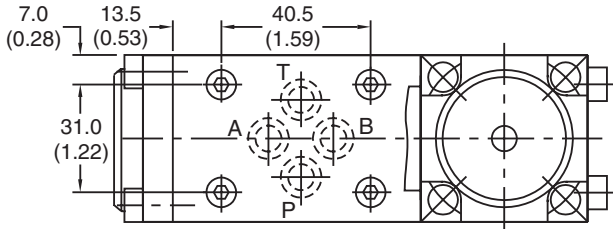

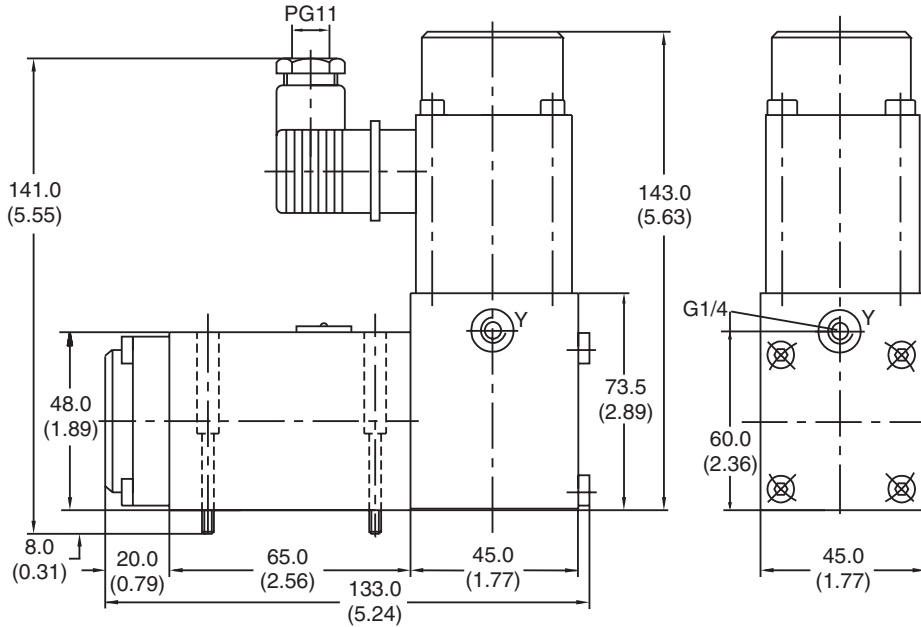

B



Port Y: G1/4

VMY*K06T:
Ports Y1 and Y2:
closed

VMY*K06N:
Drain Ports Y1 or Y2:
Port Y1 closed,
Port Y2 open

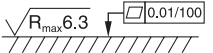
Surface Finish	Bolt kit  DIN912 12.9	 7.5 Nm (5.5 lb.-ft.)	Seal  Kit
	BK209 (4) 10-24x1.25 BK375 (4) M5x30		Fluorocarbon: SK-VB/VM-A06V

Mounting Pattern ISO 5781-03-04-0-00

Inch equivalents for millimeter dimensions are shown in (**)

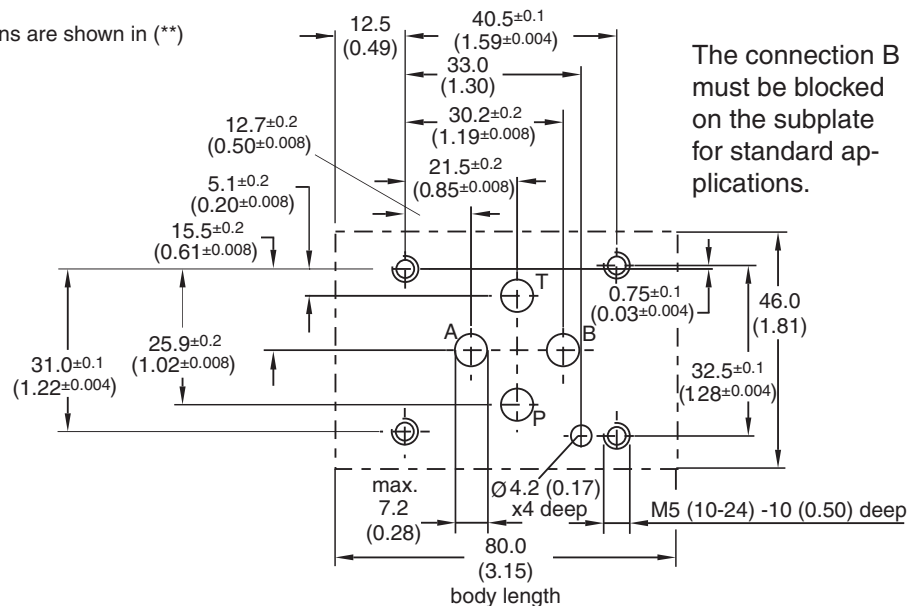



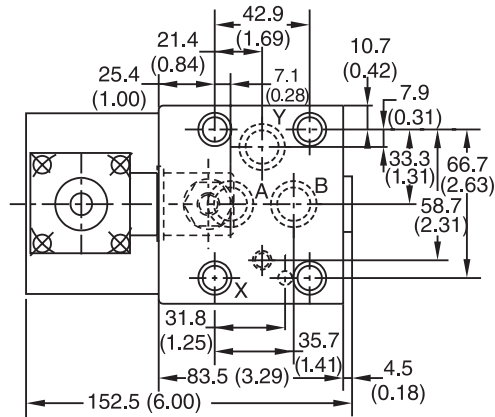

Size NG10

Inch equivalents for millimeter dimensions are shown in (**)

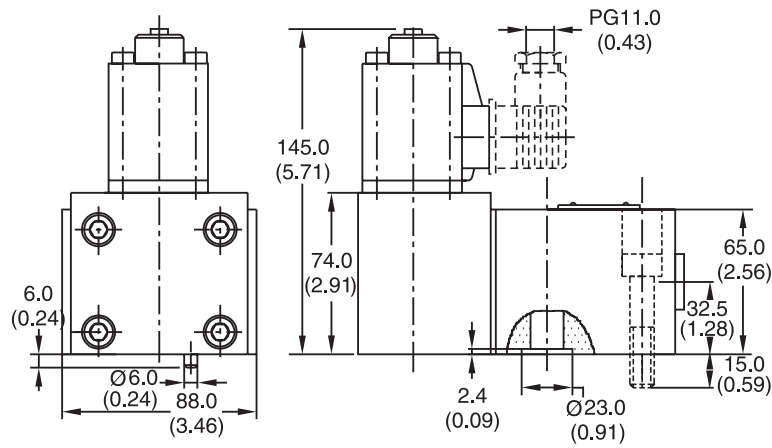

B

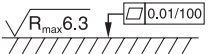

Surface Finish	Bolt kit  DIN912 12.9	 63 Nm (5.5 lb.-ft.)	Seal  Kit
	BK153 (4) 3/8-16x2 BK242 (4) M10x50		Nitrile: SK-VB/VM-A10 Fluorocarbon: SK-VB/VM-A10V

Mounting Pattern ISO 5781-06-07-0-00

Inch equivalents for millimeter dimensions are shown in (**)

